

AutoCUT 500

Fully automatic feed plate beveling machine.

PERFECT

WELD SEAMS

AUTOMATICALLY

Weld seam milling with automatic, seamlessly adjustable feed: quick, flexible and with a variable milling angle. The inlet/outlet rails make it exceptionally easy and safe to handle the AutoCUT 500.

The milling angle can be adjusted seamlessly between 15° and 60°.

- ▶ Simple, safe handling
- ▶ No restriction of the working length
- ▶ No guiding carriage is needed, therefore independent from the ground conditions
- ▶ For milling plate thicknesses from 10 mm to 40 mm
- ▶ Milling cutter with 6 carbide inserts



Chamfer width up to 30 mm



Inlet/outlet rails of the AutoCUT 500



ZFR 500 arbor milling cutter accessories



Carbide insert

Precise guidance system

Exact setting of feed rate with the seamlessly adjustable feed unit

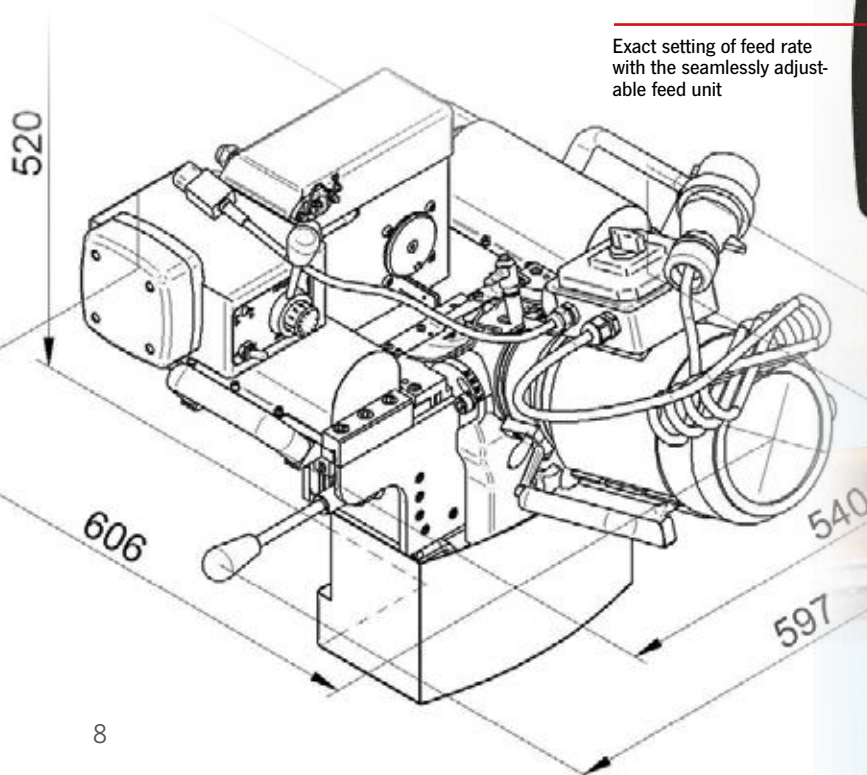



Technical data	AutoCUT 500
Chamfer angle	15°–60° seamless
Chamfer width	max. 30 mm
Cutter type	ZFR 500
Milling tool	Arbor milling cutter with six carbide inserts
Dimensions (LxBxH)	600 × 500 × 540 mm
Approx. net weight	50 kg
Voltage (see nameplate)	380 V
Motor output	1.1 kW
Speed	2750 rpm
Feed	Automatic and smoothly adjustable
Protection type	IP 20

Scope of delivery

- 1 AutoCUT 500
- 1 Arbor milling cutter with six SHM 400 carbide inserts
- 1 Operating manual
- 1 inlet and 1 outlet rail
- 1 SW 22 spanner
- 1 SW5 screwdriver with T-handle
- 1 SW6, SW8 and SW10 offset screwdriver
- 1 TX 15 screwdriver

Other optional accessories are available on page 11

